



NAVAC offers the NRS series rotary vane pumps. These are single stage, air-cooled, and direct driven for long term and continuous use. Common applications include: Analytical Instruments (mass spectrometry, SEM)

- ✓ Battery Manufacturing (Li-ion) and Solar Panels
- ✓ Food & Beverage (Thermoforming, Vacuum Packaging, Vacuum Cooling, Filling/Sealing)
- ✓ Vacuum Conveying and lifting
- ✓ Medical / Hospitals (central vacuum, surgical, R&D)
- ✓ Plastics (thermoforming, Calibration table, Extruder degassing)

DESIGN FEATURES

- Two shift gas ballast valve – allows for the different requirements of condensable gases to be exhausted.
- High efficiency oil mist filters prevent smoking and oil vapor exhausting into the equipment space while also prolonging the service life.
- Dual automatic anti-suckback design – protects vacuum system from oil contamination in the event of an unexpected shutdown.
- Sealing parts are made from FPM improving the anti-corrosion performance and preventing oil leakage.
- Integrated pump and motor design.

NRS100 Flow Rate Characteristic

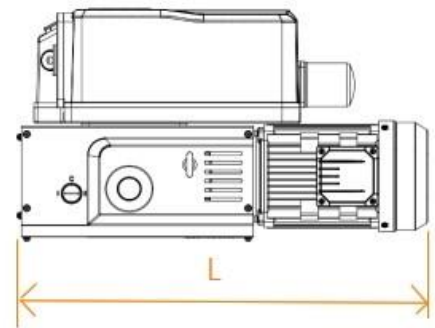
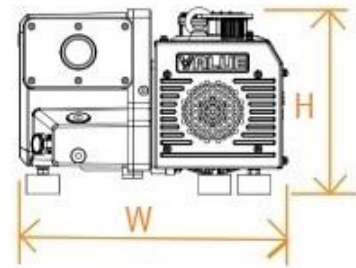
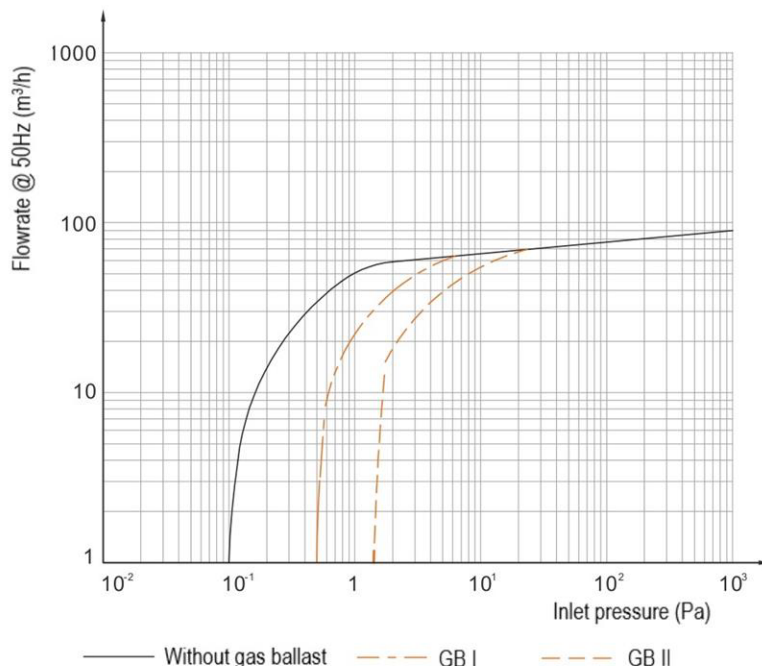

TECHNICAL DATA



Pumping Speed (m ³ /h / cfm)	50 Hz	100 / 58.9
	60 Hz	119 / 70
Rotational Speed	50 Hz	1440
	60 Hz	1720
Ultimate Total Pressure	torr	2.25 x 10 ⁻¹
	mbar	3.00 x 10 ⁻¹
Ultimate Total Pressure - GB I	torr	3.75 x 10 ⁻¹
	mbar	5.00 x 10 ⁻¹
Ultimate Total Pressure - GB II	torr	1.125
	mbar	1.5
Standard Cooling Method		air
Dimension (L x W x H)	in	27.7 x 16 x 11.3
	mm	703 x 406 x 286
Weight	(lb/kg)	155 / 70
Connection ports (inlet / outlet)		G 1 1/4"
Power Rating	kW	2.2
	hp	3
Oil Capacity	ml	5000
Sound emission	dB(A)	≤ 62
Water Vapor Tolerance - GB I	torr	11
	mbar	15
Water Vapor Capacity - GB I	kg/h	0.8
Water Vapor Tolerance - GB II	torr	22
	mbar	30
Water Vapor Capacity - GB II	kg/h	1.6
Protection Category		IP54
Ambient Temperature range	°C	10 - 40

ORDERING INFORMATION

Product Description	Order No.
200-220/380-415V, 50Hz, 200-230/460v, 60Hz, 3 ph	N201001001
Service Kit	NSK100
Oil Mist Filter	320750602
Oil Filter	320750421

442 5927 114
 info@hivac.us
 www.hivac.us

Retorno Universitario 1 Int. 53-B, Terra Business Park,
 El Marqués, Querétaro, Qro. CP 76269