



NAVAC offers the NRD and NRD M series rotary vane pumps. These are UL listed, two-stage, air-cooled, and direct-driven for long term continuous use. Typical applications include:

- ✓ Analytical Instruments (mass spectrometry, leak detection, RGA)
- ✓ Medical Equipment (plasma sterilizers, pharma freeze drying)
- ✓ Industrial Coatings (thin films, vacuum ovens, furnaces)
- ✓ Controlled Environment Horticulture (extraction, vacuum ovens)
- ✓ HVAC (refrigerant charging, helium leak detection and recovery)
- ✓ Electronics, Power, Gas Recovery, etc...
- ✓ General laboratory use (backing for turbo-pump, central vacuum)

DESIGN FEATURES

- Adjustable gas ballast valve – allows for the different requirements of condensable gases.
- Dual automatic anti-suckback design – protects vacuum system from oil contamination in the event of an unexpected shutdown.
- Forced oil circulation – ensures stable vacuum
- Integrated cylinder structure and pin connection – convenient and accurate for maintenance/inspection.
- M series pumps were specifically created for the plasma sterilization industry to handle the mild corrosiveness of H_2O_2 in the process. Excellent for freeze drying applications' high H_2O vapor content.

NRD48 Flow Rate Characteristic

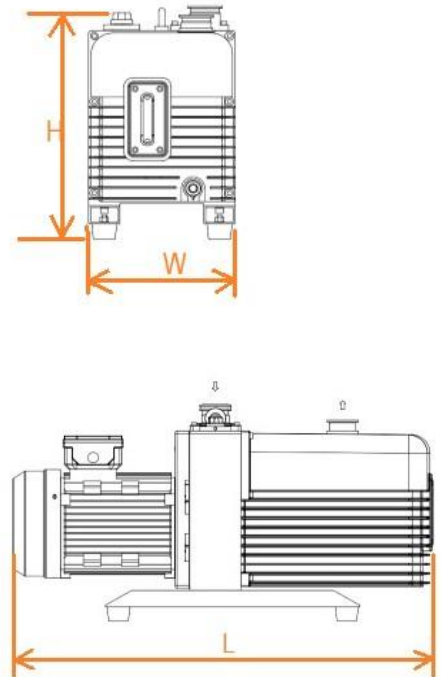
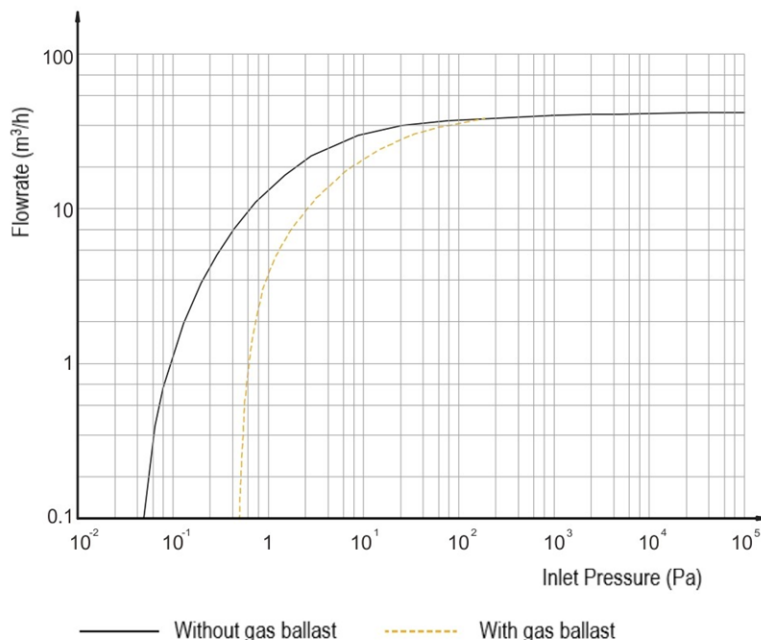

TECHNICAL DATA



Pumping Speed (m ³ /h / cfm)	50 Hz	48 / 28.3
	60 Hz	57.8 / 34
Rotational Speed	50 Hz	1440
	60 Hz	1720
Ultimate Total Pressure	torr	3.75 x 10 ⁻³
	mbar	5.00 x 10 ⁻³
Ultimate Total Pressure w/ GB	torr	2.25 x 10 ⁻²
	mbar	3.00 x 10 ⁻²
Standard Cooling Method		air
Dimension (L x W x H)	in	28.3 x 9.2 x 14.1
	mm	720 x 234 x 358
Weight	(lb/kg)	137 / 62
Inlet / Outlet Ports		KF40
Power Rating @ 60Hz 3-ph	kW	1.5
	hp	2
Oil Capacity	ml	4000
Sound emission	dB(A)	≤ 62
Water Vapor Tolerance	torr	15
	mbar	20
Water Vapor Capacity	kg/h	0.7
Protection Category		IP44
Ambient Temperature range	°C	5 - 40

ORDERING INFORMATION

Product Description	Order No. (Standard)	Order No. (M Series)	Order No. PFPE prepped	Order No. (M Series, PFPE prepped)
200-220/380-415V, 50Hz, 200-230/460v, 60Hz, 3 ph	N10481001	N10481001M	N10482001	N10482001M
Oil Mist Filter	NOT65C	NOT65C	NOT65C	NOT65C
Oil	NPO100H (4L)	NPO100H (4L)	* Prep Only *	* Prep Only *
Repair Kit	NSK48	NSK48M	NSK48	NSK48M